

Time setting state

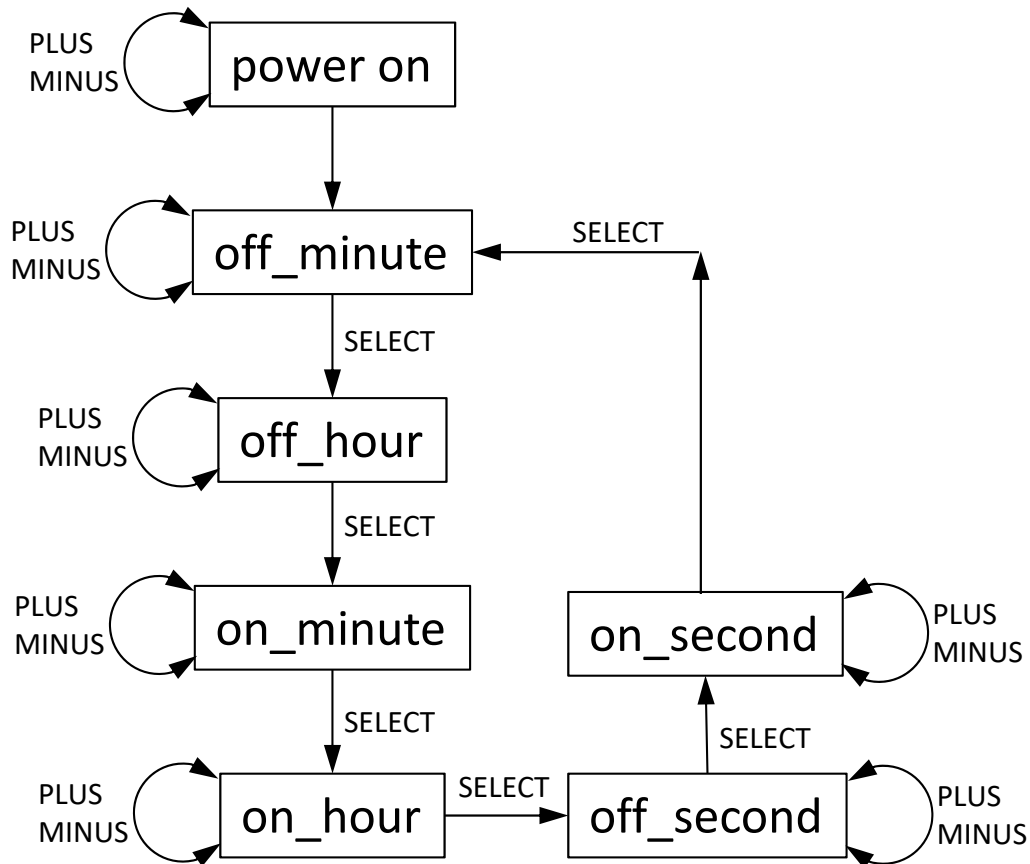

count control state

